

Alarm Power Supply

Circuit :Ron J

Email: anc@mitedu.freeseve.co.uk

Description:

A 12 Volt power supplied designed for Ron's Modular Burglar Alarm. However, being a popular supply voltage this circuit will have many other uses as well.

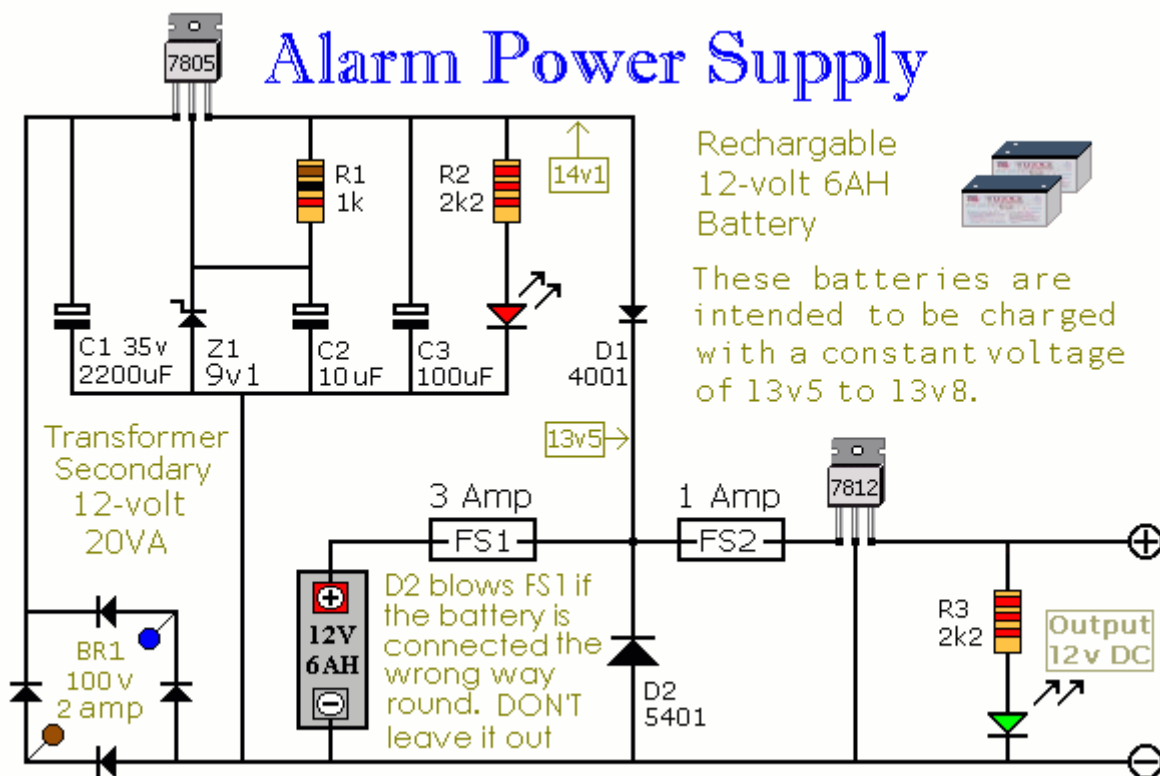

Notes:

This Power Supply is suitable for the Modular Burglar Alarm. However, it has other applications. It is designed to provide an output of 12-volts, with a current of up to 1-amp. In the event of mains failure, the back-up battery takes over automatically. When the mains is restored, the battery recharges. Use a genuine alarm type back-up battery. They are maintenance-free, and their terminals can be held at 13v8 for many years, with no ill effects. A smaller or larger capacity battery may be used, without circuit modification. Use the 2-amp version of the 7805. It needs the larger heatsink because it has to dissipate a lot of energy, especially when called upon to recharge a flat battery. This heatsink is at 9v1, and must NOT be connected to ground. The 7812 never has to dissipate more than 2-watts, so its heatsink can be smaller. Many of the components, which are shown lying flat on the board, are actually mounted upright. The links are bare copper wire on the component side. The heatsinks are folded strips of aluminium, about 2mm thick. Use a well-insulated panel mounted fuse holder for the mains supply to the transformer, and fit it with a 1-amp fuse.

Alarm Power Supply component side

